

High Volt DC100~240V LED Strip DMX Controller

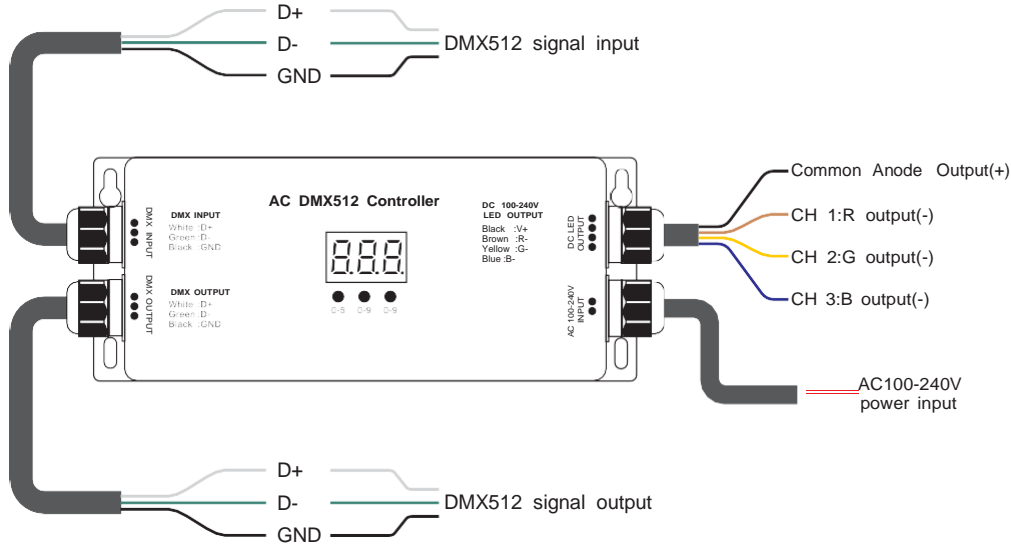

Important: Read All Instructions Prior to Installation

Function introduction



Product Data

Input Voltage	Output Voltage	Output Current	Max Load	Size(LxWxH)
AC 100-240V	DC 100-240V	Max 3x1.66A	500W@110V 1000W@240V	180.5x73.6x38mm

- Standard DMX512 compliant control interface, enable to set the DMX address freely. And show address Via digital numeric display.
- Safe and reliable full isolation design
- Output for high voltage DC100~240V LED Strip
- With both Master / Decoder functions switchable.
- High temperature resistant address digital display.
- Waterproof grade:IP67

Safety & Warnings

- DO NOT install with power applied to device.
- This device is IP67 rating and protected against damp environment.

Operation

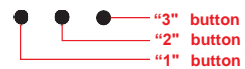
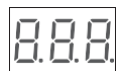

- A. Choose mode**
Hold button 1 & 2 together until **ru** digital display flashes, click button 3 to choose 1 or 2.
ru1 is DMX Master mode, **ru2** is DMX Decoder mode.
After choose ru1 or ru2, then hold any one button to confirm the setting.

B. Set DMX Decoder Address

If the controller at DMX Decoder mode **ru2**, you need to set the DMX address by holding any one of the buttons until the display flashes, then click the buttons to set address, then hold any one button to confirm the setting.

C. Set DMX Channels

After setting the controller at DMX Decoder mode **ru2**, you can set the DMX channels by holding button 2 & 3 together until display flashes, then click button 1 to choose 1 or 3, then hold any one button to confirm the setting.

3cH means the decoder occupies 3 dmx address, usually for RGB LED strip. **1cH** means the decoder occupies 1 dmx address, usually for mono LED strip.

Note: the factory defaults setting is DMX Decoder mode ru2, 3cH

Instruction for Master mode **ru1**

1. All the connected DMX decoders should be address 001 only.
2. After set the controller to be DMX Master mode, you can adjust its programs, brightness, speed.

3. Keep on clicking button 1 you can get **P.S.b.c**

P means program, keep on clicking button 3, to play 10 running programs.

S means speed, keep on clicking button 3, to adjust the speed of running programs. From **5-1** to **5-9**, speed turns slower and slower

b means brightness, keep on clicking button 3, to get 8 levels of brightness. From **b-1** to **b-8**, brightness turns more and more bright

c means color, keep on clicking button 3, to get total 9 static colors.

Wiring diagram

Wiring as DMX Decoder Mode **ru2**

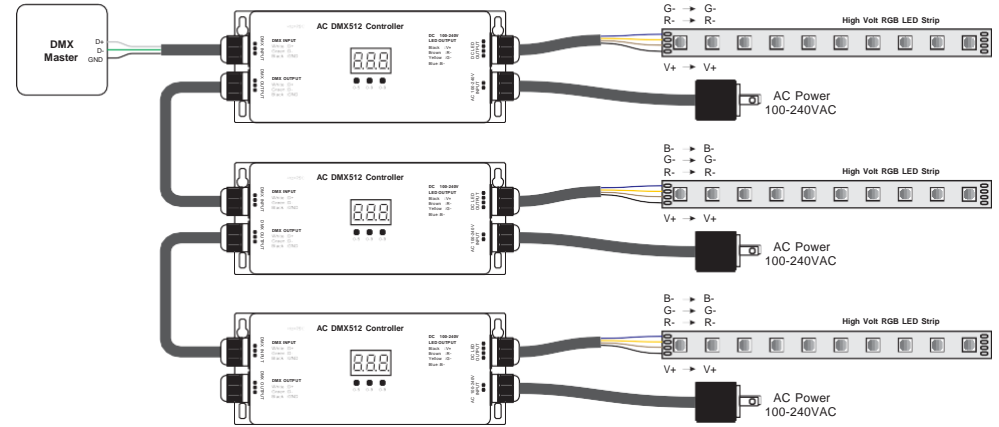

Wiring as DMX Master Mode

